



SERVO-HYDRAULIC UNIVERSAL TESTING MACHINE  
SERIES DP

---





## STANDARD

---

AC 133: 2010: 4.1, BS 8110: PART 1: 1997 3.12.8.16.2, BS4482, BS4483, BS4449  
ASTM A 1034: 10.5, 10.7

## TEST TYPE

---

- Slip & Tensile Strength
- Permanent Elongation & Tensile Strength
- Static Tension Test
- Static Compression Test
- Cyclic Tension & Compression Test

## DESCRIPTION

---

RoboTest Series DP servo-hydraulic universal testing machine is designed with up-mounted actuator structure. Bidirectional differential cylinder provides bidirectional control of tension and compression in one single space. Advanced side action hydraulic tensile grips provide high gripping performance for high strength and high hardness materials without any initial gripping force.

Clearance-free structure and actuator up and down to adjust the test space offers easy operation and high efficiency. This machine is mainly used for tensile test of metallic materials. It provides closed loop control of constant force, constant displacement and constant extension, smoothly switching among them.

Test results can be automatically calculated and be able to printed and exported.

**Load Frame Configuration:** 4 columns, servo-controlled hydraulic

**Capacity:** 600kN, 1000kN, 2000kN

**Test Space:** Single zone

**Typical specimens:** Fasteners, rebar, chain, welds, castings

## FEATURES

### LOAD FRAME

1. Single zone design ensures all types of tests finish in one space. Compact and reasonable design is ergonomic and effectively reduces labor intensify.
2. Upper actuator features excellent axis alignment, good shock absorption and easy to adjust test space.
3. Advanced wedge type hydraulic tensile grips provide high gripping performance for high strength and high hardness materials.
4. long travel double-acting cylinder can accommodate different specimen size. One-body forging piston and rod, and imported sealing components, ensure perfect sealing, high accuracy and repeatability.
5. Robust and high-accuracy guidance protects cylinder from lateral force, improving the working life of sealing components.
6. "I" shape force transducer features excellent linerity and stability with ultra measurement accuracy.
7. Nemicon encoder provides with high accuracy of displacement measurement and control
8. DDV D633 MOOG servo valve offers fast response and high-accuracy control, and easy to maintain.
9. Equipped ABB motor features high efficiency, energy-saving, high start-toque, good performance, low noise, low shaking, high reliability and easy to maintain.

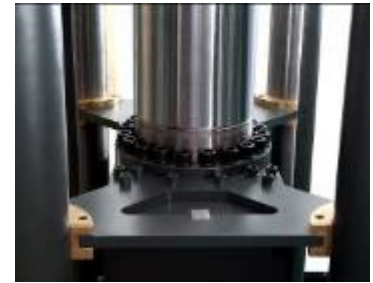



## MAIN CYLINDER

- Piston rod is Nickel and Chrome plated. Plating thickness can reach 0.1mm with strong anti-corrosion and anti-wearing ability.
- Extra thick rod ensures high stiffness to resist lateral loading.
- Piston and rod are one-body forging with strong impact resistance.
- Sealing components are Hallite U shape and double sealing ring, ensuring zero leakage.
- Hallite guidance wearing ring is applied to ensure high resistance to lateral force and low friction.
- Main cylinder matching with differential circuit allows fast return of piston.
- Zero clearance and pre-loading connection between piston rod and upper grip guarantees high reliability.
- RoboTest uses most advanced Piston / guide sleeve copper melting process as wearing ring, with service life five times than polymer material.



## SIDE ACTION HYDRAULIC GRIP

RoboTest's dual side-acting grips incorporate our latest patented technology. This self-centering mechanical synchronizer provides many improvements over hydraulic or mechanical rack and pinion designs commonly found in the marketplace.

- Side-load dampening reduces the risk of grip damage when testing slightly bent or irregularly shaped specimens such as rebar or wire rod
- Opposing jaw faces repeatedly self-center during specimen clamping reducing testing time and eliminating the need to resynchronize the grip faces between tests
- The synchronizer is located outside the gripping pocket preventing mechanical failure due to contamination
- Tensile tests on a wide range of materials including: steel rod and plate, machined rounds and flats, reinforcement bar, 3- and 7-wire strand, conveyor belt, and wood products

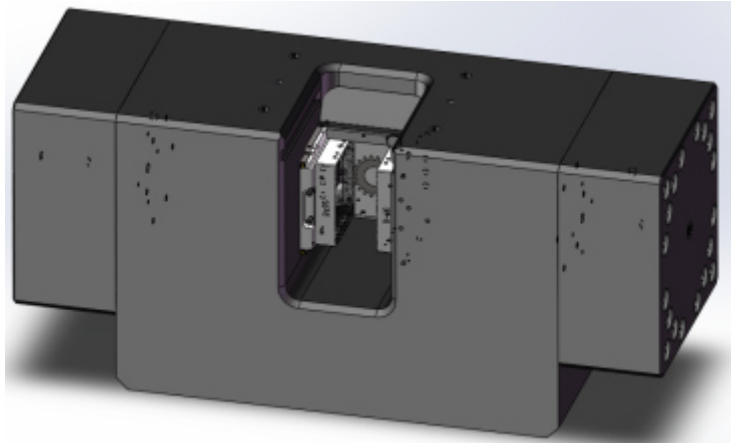

Jaw faces





## HYDRAULIC POWER UNIT

- Equipped with SUN Cartridge logic valve in the hydraulic system of the equipment, it can be smart regulation of system pressure. The pressure servo technology can guarantee that the system pressure is always only higher than the cylinder pressure 1MPa, when the test force is low, the pump output pressure is lower, when the test force increases, pump output pressure increases the proportion too.
- The differential pressure is adjustable to ensure no shaking during test, thus saving energy and reducing heating
- Low noise: NACHI Japan gear pump, combined with our technology of HPU production, its noise is not more than 70dB, improving the working conditions of workers.
- Easy installation and maintenance: The hydraulic unit is designed with semi-open structure. Rear cover opens two doors, easy maintenance and parts replacement.
- Low heating and good cooling: The unique pressure differential servo control technique makes the system heat significantly reduced. The hydraulic unit is designed with semi-open structure and air-cooling device. Cooling devices can start automatically or manually. The air-cooling motor automatically starts when the temperature reaches the preset value of oil temperature gauge, making the system in high temperature environment continue to work normally. The whole system heating power is 2kW.
- High filtration precision: triple filter, the particle size is less than 5 microns before entering the servo valve, improving the service life of the servo valve and control accuracy, easier to maintain.
- Pressure overload protection: when the pressure exceeds the system rated pressure, relief valve will begin to overflow, to ensure the security of the entire system.
- Seal method: the hydraulic lines from the tubing to the connector are equipped with Eaton products from USA. Piping lines are sealed with high-pressure hose sleeve type Cone fittings with excellent sealing performance, which can be repeated assembly and disassembly. Cylinder piston rod and piston seal are used with British Hallite patented Hythane U- seals and dust ring , at the



same time with Hallite high anti-lateral pressure and low friction rate of large-size guide ring , offering high ability to resist lateral force, thus to ensure cylinder of zero leakage and long service life.

- The advantages of the HPU: HPU consists of 25MPa high-pressure part and 50MPa super high pressure part. The main cylinder working pressure is around 25MPa and the clamping cylinder working pressure is around 48MPa. Only one motor drives oil pump. Through the booster to gain extra-high pressure, thus with lower noise.
- The system has two sets of differential circuit. One is for main cylinder, so that after the end of the test, the main cylinder piston can faster return to improve work efficiency. Another is for the clamping cylinder. Clamping cylinder allows fast and low pressure gripping the specimen. Only after samples are fully clamped, extra-high pressure can be supplied, avoiding damaging sample because of too high clamping force. After specimen is broken, high pressure will be automatically released.

## CONTROLLING SYSTEM – DTC-350

### 1. Closed loop control of stress, strain and displacement.

Control loops can switch automatically and smoothly. Control algorithm adopts advanced neural element self-adapting PID. Neural element has ability of close to any non-linear function , simple structure and learning algorithm. It can adapt changing of control object by changing its own synapse weighting and distinguish parameter on line, rebuild object model on line.



### 2. Control system based on DSP

DSP, the professional CPU and RISC, is used as control chip of the products. The chip has many functions, such as 40MIPS, 32-digit fixed point, vector control, A/D exchange, position capturing , etc. It is a CPU widely used in industry controlling and suitable to be IC of our products.

### 3. USB 2.0 communication

Data exchange between hardware and software via USB 2.0 inrerface and velocity of 12Mb/s. USB is main direction of development of communication, which has merits of high communication velocity, variety of communication mode( such as controlling , breaking, batch, real time ,etc.), and will be the main mode of communication.



#### 4. Data acquisition system and position capturing system.

Data acquisition system consists of 8 channels of 24 bit A/D exchange; effective resolution is 1/350000 with non-step in full range . Exchange velocity and gain are programmable on line. The products contain 3 channels of encoder position capturing system permitting photo-electric orthogonal code impulse. Frequency can reach 5 MHz, which has functions of correcting, direction identifying and number-counting.

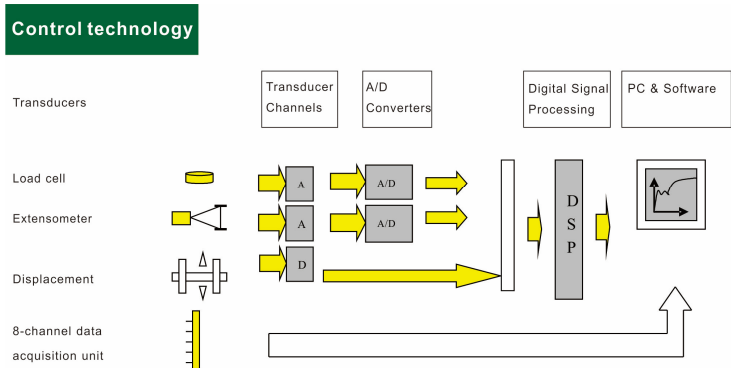





## PROFESSIONAL TEST SOFTWARE

This software features a large, growing host of pre-packaged test methods to help you quickly and efficiently meet the requirements of global test standards such as ASTM, ISO, DIN, EN, BS, and more. Selected by an operator at runtime, these methods are crafted to meet the specific test flow, analysis and reporting requirements of industry standards across a range of specimen and test types. Pre-packaged test methods are available in a wide selection of bundled sets, including: Polymers & Plastics, Metals, Construction Materials, Biomedical Products, Paper Products, Adhesives, foam, textiles and more.

- Versatile, easy-to-use TestPilot software with a large and growing library of standards-compliant test methods (ASTM, ISO, DIN, EN, BS, and more)
- Modular design permits easy upgrading
- Plenty of test standards are built in the library of the software for routine tests.
- User configured report: user can preset report template and include necessary information, like company information, statistics, and etc. Test report can export to Excel or Word.
- Powerful graphic function: real time display curves, like displacement-load, stress-strain, displacement-time, load-times, and others
- Powerful analysis function can calculate typical value and display on the curve, like Fm, ReL, ReH, Rp.
- Measurement unit: Users can select SI, or others, like N, kN, Kgf, lbf, Mpa, and so on, user can define the unit by themselves using formula.

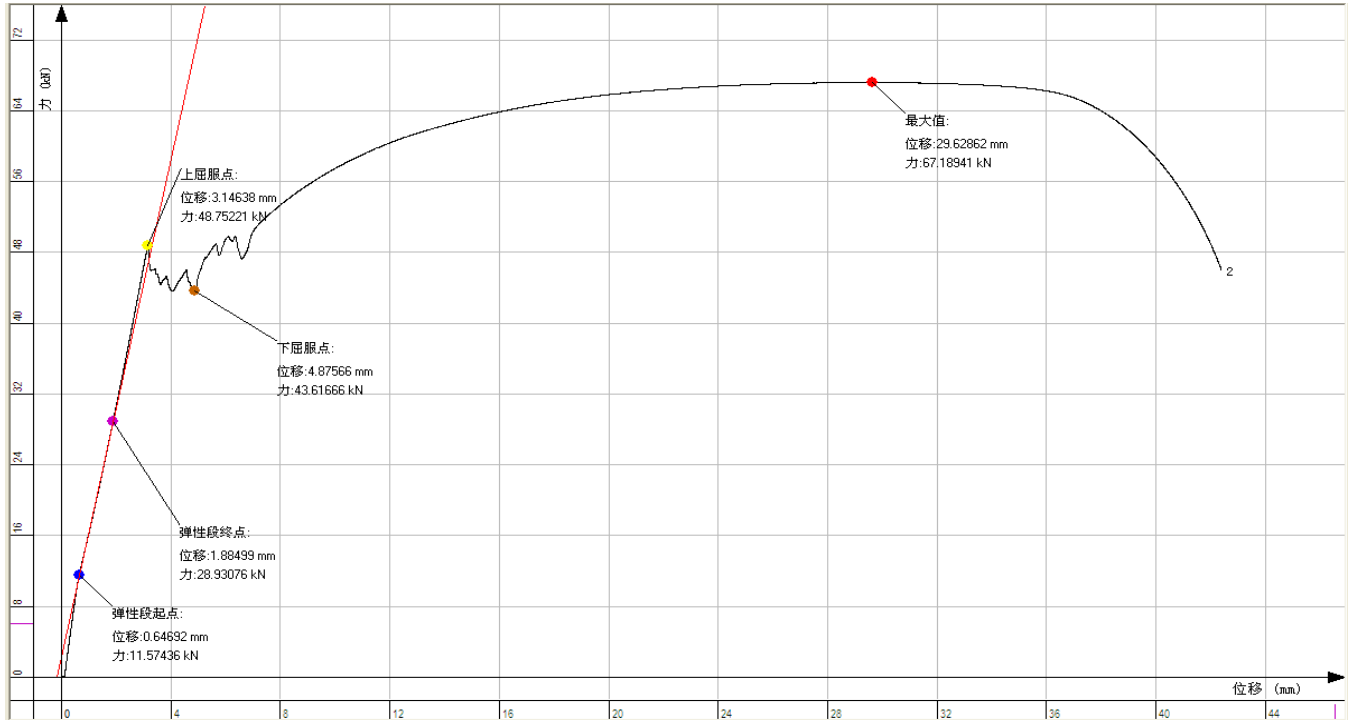

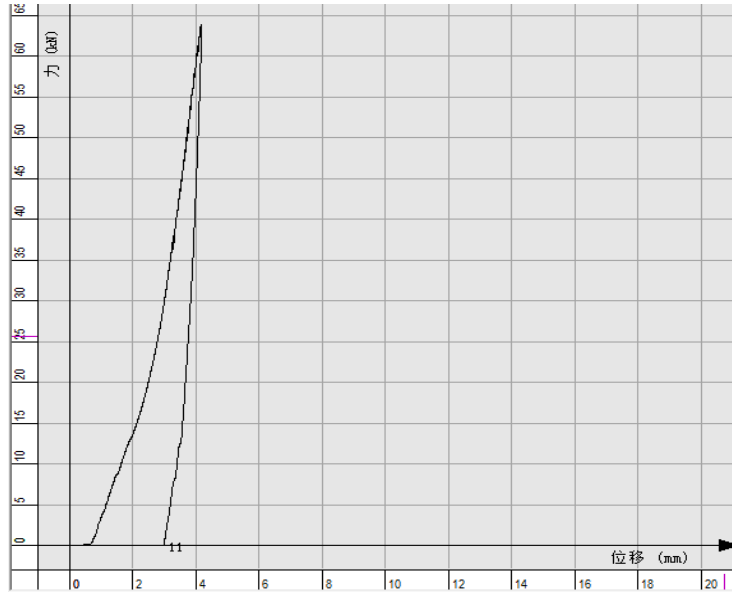

Slip test

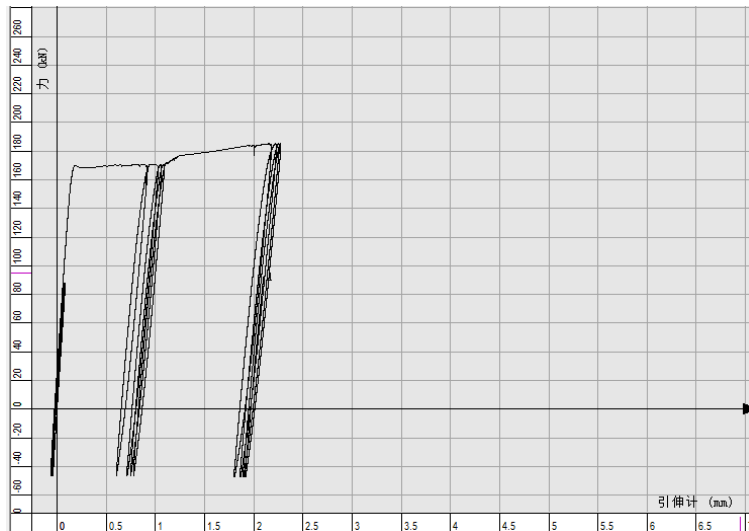

Tension & compression cyclic test

### MACHINE DIMENSION

Model	Dimension (mm) A×B×C	Effective tensile space (mm) D	Maximum compression space(mm) E	Distance between columns (mm) F×G	Piston travel
RHTM605DP	880×630×2980	580	450	600×350	560
RHTM106DP	980×720×3590	680	550	660×400	650
RHTM206DP	1220×880×4100	800	580	900×450	780

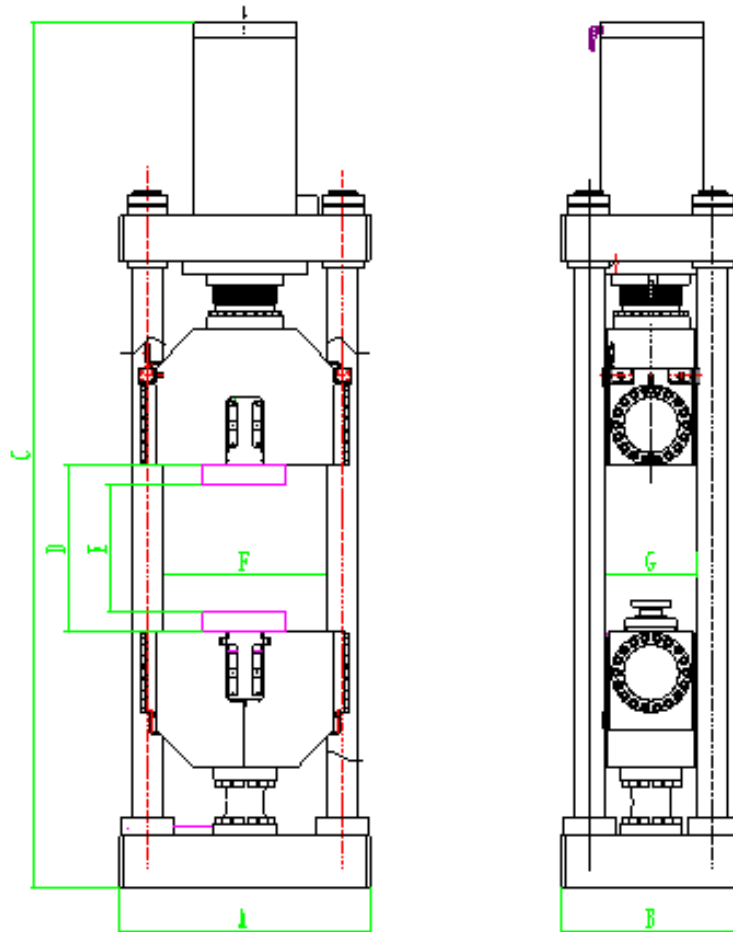



## SPECIFICATIONS

Model	RHTM605	RHTM106	RHTM206
Type	Series DP		
Capacity (kN)	600	1000	2000
Calibration accuracy	Class 1 / Class 0.5		
Force accuracy	Better than $\pm 1\%/\pm 0.5\%$		
Force range	1% ~ 100%FS		
Displacement resolution	0.008mm		
Displacement accuracy	Better than $\pm 1\%/\pm 0.5\%$		
Extension range	1% ~ 100%FS		
Extension accuracy	Better than $\pm 1\%/\pm 0.5\%$		
Extension resolution	1/350000 of max extension		
Force loading speed	0.02%~2%FS/s		
Actuator (piston) up speed (mm/min)	190	180	200
Actuator (piston) down speed (mm/min)	240	290	300
Force loading speed	0.02%-2% FS /s		
Column number	2	4	4
Distance between columns (mm)	600	660×400	900×450
Maximum tension space (mm)	580	680	780
Maximum compression space (mm)	450	550	580
Diameter of round specimens (mm)	$\phi 10-\phi 40$	$\Phi 15-\phi 55$	$\phi 15-\phi 70$
Thickness of flat specimens (mm)	2-30	2-40	10-70
Compression platen	$\phi 150$	200×200	$\Phi 200$
Actuator (piston) stroke (mm)	560	650	780
Frame dimension (LxWxH) (mm)	880×630×2980	980×720×3590	1220×880×4100
Hydraulic Power Unit dimension (LxWxH) (mm)	710×1080×1050	710×1080×1050	1210×860×1350
Oil tank capacity (Liter)	160	160	320
Anti-wear hydraulic oil	#46		
Power consumption (kW)	8		
Power supply	3-phase, 5-line, AC380V, 50Hz		
Frame weight (kg)	3500	6500	9000