

PNEUMATIC SIDE ACTION TENSILE GRIP – RTQA102A

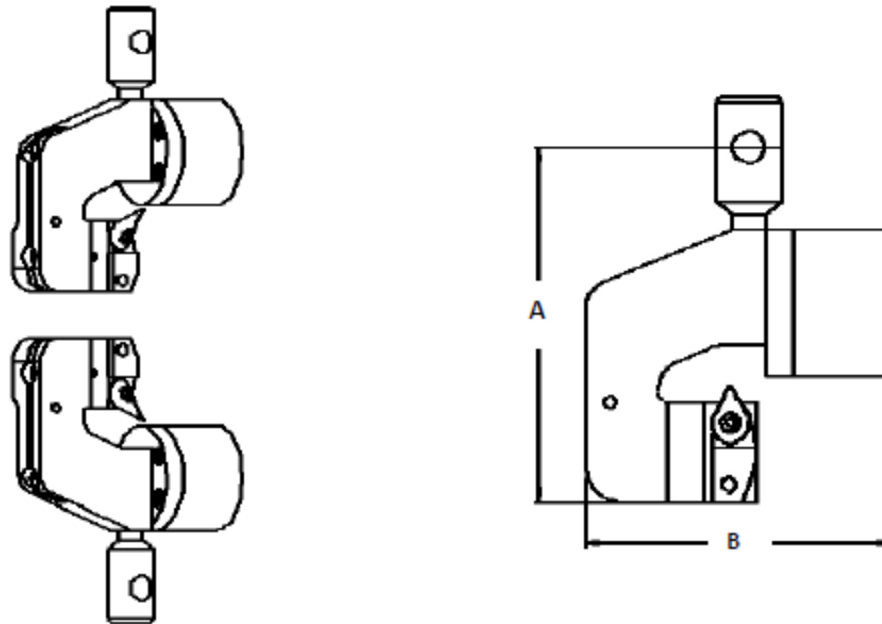

Application	Tensile test of mono-filaments, cord and yarn	Maximum force	100N
Connection		Height (A)	
Upper grip	Φ10mm pin	Upper grip	108mm
Lower Grip	Φ10mm pin	Lower grip	108mm
Grip body width(B)	93.3mm	Clamping type	Pneumatic side action
Upper grip weight	0.42kg	Lower grip weight	0.42kg
Jaw face height	57mm	Jaw face width	60mm
jaw face	Flat jaw	Specimen diameter	< Φ1mm

PNEUMATIC TENSILE GRIP – RTQA303E

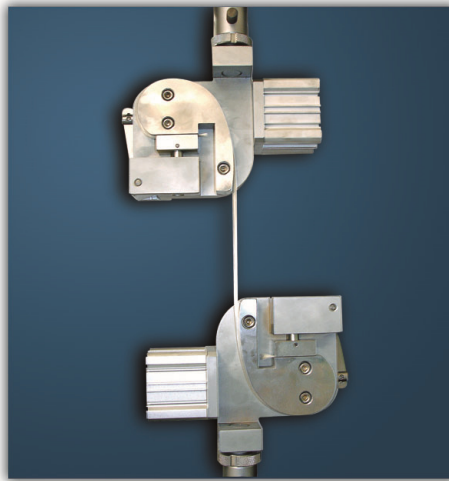

Application	Tensile test of fiber glass, cotton thread, Nylon cord	Maximum force	3KN
Connection		Height (A)	
Upper grip	Φ10mm pin	Upper grip	180mm
Lower Grip	Φ10mm pin	Lower grip	180mm
Grip body width(B)	185mm	Clamping type	Pneumatic and wrapping
Test space needed	20mm	Temperature	Ambient
Upper grip weight	4.5kg	Lower grip weight	4.5kg
Jaw face height	150mm	Jaw face width	40mm
jaw face	Rubber coated	Specimen diameter	Φ4mm

PNEUMATIC SIDE ACTION TENSILE GRIP – RTQB502A

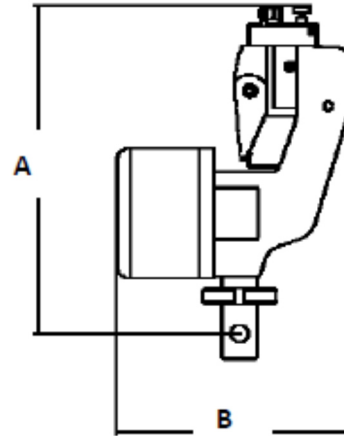
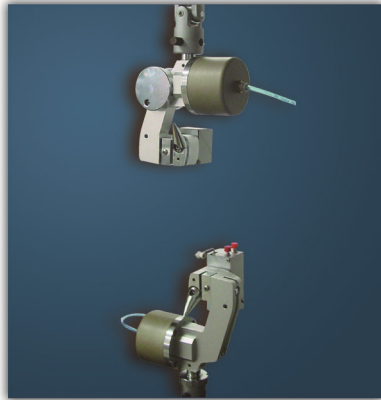

Application	Tensile test of mono-filaments, cord and yarn	Maximum force	500N
Connection Upper grip Lower Grip	$\Phi 10\text{mm}$ pin $\Phi 10\text{mm}$ pin	Height (A) Upper grip Lower grip	170mm 190mm
Grip body width(B)	140mm	Clamping type	Pneumatic single moving face clamping
Upper grip weight	1.5kg	Lower grip weight	1.7kg
Jaw face height	36mm	Jaw face width	16mm
jaw face	Rubber coated flat jaw	Specimen diameter/thickness	<3mm

PNEUMATIC SIDE ACTION TENSILE GRIP – RDQB102A

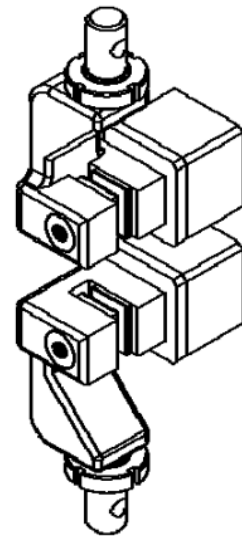
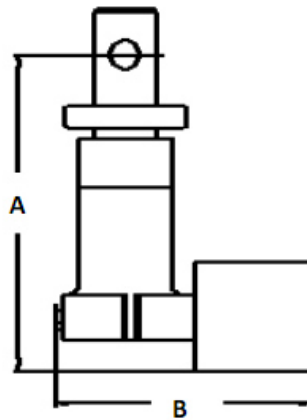
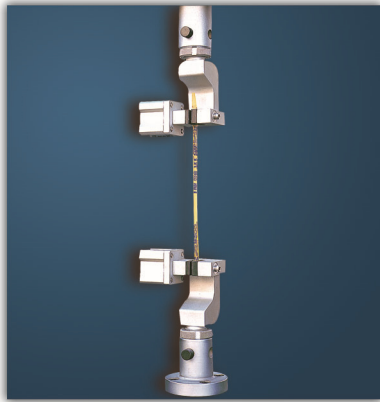

Application	Tensile test of plastic film	Maximum force	100N
Connection		Height (A)	
Upper grip	Φ10mm pin	Upper grip	94mm
Lower Grip	Φ10mm pin	Lower grip	94mm
Grip body width(B)	82mm	Clamping type	Pneumatic side action
Upper grip weight	0.38kg	Lower grip weight	0.38kg
Jaw face height	15mm	Jaw face width	22mm
jaw face	Rubber coated flat jaw	Specimen thickness	0~3mm

PNEUMATIC SIDE ACTION TENSILE GRIP – RDQB104B

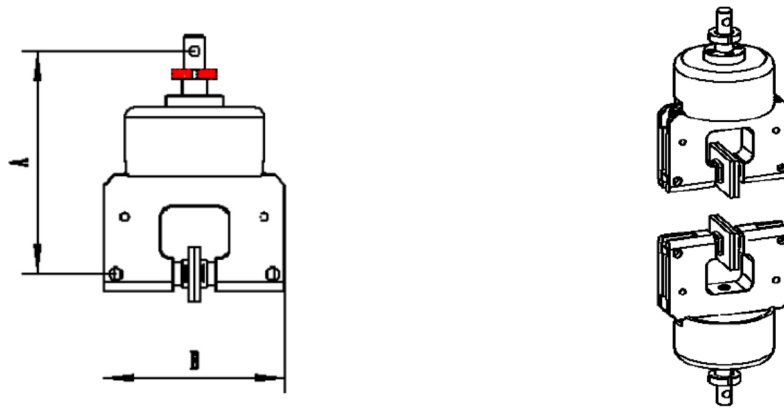

Application	Tensile test of textile, grab test	Maximum force	10KN
Connection		Height (A)	
Upper grip	Φ10mm pin	Upper grip	205.5mm
Lower Grip	Φ10mm pin	Lower grip	205.5mm
Grip body width(B)	170mm	Clamping type	Pneumatic side action
Test space needed	411mm	Temperature	Ambient
Upper grip weight	7.9kg	Lower grip weight	7.9kg
Grip Jaw opening	0~14mm	Rubber coated Jaw face	25.4 x 25.4mm
Rubber coated Jaw face	50.8 × 76.2mm	Diamond jaw face	25.4 X 50.8mm

Note: 1) Jaw face can be customized. 2) Jaw face is exchangeable.

PNEUMATIC SIDE ACTION TENSILE GRIP – RDQA502A

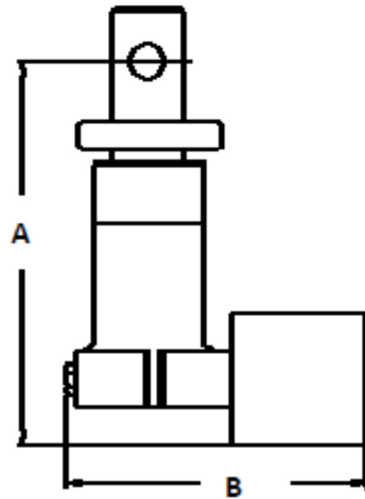

Application	Tensile or peel test of package materials, plastic or plastic film	Maximum force	500N
Connection		Height (A)	
Upper grip	Φ10mm pin	Upper grip	118mm
Lower Grip	Φ10mm pin	Lower grip	118mm
Grip body width(B)	105mm	Clamping type	Pneumatic side action
Upper grip weight	0.35kg	Lower grip weight	0.35kg
Jaw face	Flat jaw	Jaw height	3mm
Jaw width	25mm	Specimen thickness	0~4.5mm

PNEUMATIC ACTION TENSILE GRIP – RDQB303A

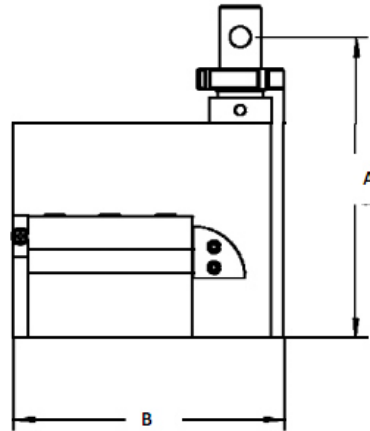
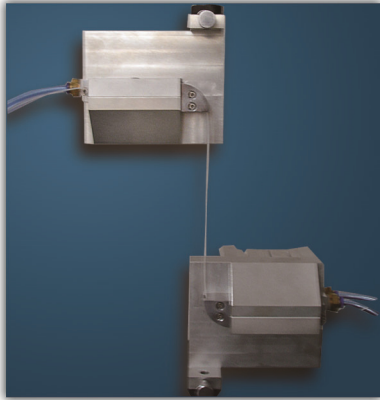

Application	Tensile test of non-metallic thread and fishing line	Maximum force	3KN
Connection		Height (A)	
Upper grip	Φ10mm pin	Upper grip	145mm
Lower Grip	Φ10mm pin	Lower grip	145mm
Grip body width(B)	125mm	Clamping type	Pneumatic side action
Upper grip weight	1.6kg	Lower grip weight	1.6kg
Jaw face	Flat jaw	Jaw height	76mm
Jaw width	10mm	Specimen thickness	0~3mm

PNEUMATIC ACTION TENSILE GRIP – RDQC502B

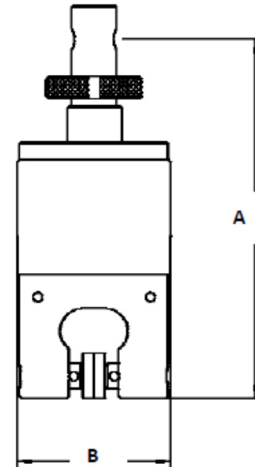

Application	Tensile or peel test of package materials, plastic or plastic film	Maximum force	500N
Connection Upper grip Lower Grip	Φ 10mm pin Φ 10mm pin	Height (A) Upper grip Lower grip	160mm 160mm
Grip body width(B)	70mm	Clamping type	Pneumatic side action
Upper grip weight	1kg	Lower grip weight	1kg
Jaw face	Serrated jaw	Jaw height	20mm
Jaw width	50mm	Specimen thickness	0~12mm

PNEUMATIC SIDE ACTION TENSILE GRIP – RTQA105C

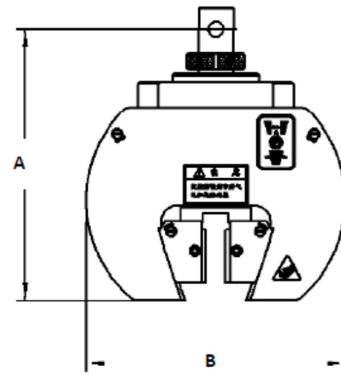

Application	Tensile test of metallic materials	Maximum force	100KN
Connection		Height (A)	
Upper grip	Φ18mm pin	Upper grip	320mm
Lower Grip	Φ18mm pin	Lower grip	320mm
Grip body width(B)	300mm	Clamping type	Pneumatic wedge action
Upper grip weight	30kg	Lower grip weight	30kg
Jaw height	20mm	Jaw width	50mm
Round specimen	Φ4~ Φ9mm Φ9~ Φ14mm Φ14~ Φ21mm	Flat specimen thickness	0~10mm, 10~21mm